

Dry Measuring of International One Metres

When a new IOM is to be measured for its certificate the owner faces, what in effect is a two-step process. Having passed the fundamental measurement and clutching the new certificate the owner can quite happily race his IOM and never see the second step until going to an event such as a national championship. This in North America, for example where skippers and tanks are far apart, can mean that after travelling 5,000 Km the owner finds his boat to be not really an IOM when it fails in the tank. The usual reason being the bulb draught measurement.

When the IOM was conceived and its rules established the class opted for using the boat's waterline as its datum for the measurement of its three limits - overall length, hull draught and ballast draught. In addition to these three measurements nothing may extend beyond the boats overall length. None of these are required to be checked for the boats fundamental measurement for its certificate. However, they are invariably checked at major events.

This use of the waterline was obviously thought to be a good idea at the time. The catch is the requirement for a boat being measured has to be floated to find the waterline and check the above measurements. To achieve this as we all know a tank is required. For the past decade, or more, there have been rumblings of discontent centred on the tank and several moves towards replacing the tank measurement with waterless measurement. I refer you the IOMICA Forum for further reading on the subject.

The following is a summary of perceived problems with tank / wet measurement.

1. It is not particularly accurate in that establishing the datum water level is not easy thanks to the surface tension of water and this results in the draught measurements being suspect.
2. In making a tank by simple processes it is not easy to establish the hull draught indicator.
3. In use it is slow both in the initial set up and in the cycling of boats - especially when many approach the maximum draught.
4. It is bulky to transport and store.
5. The boats must be in rigged sailing trim which when the tank is in use out of doors causes problems whenever there is wind.
6. A perception exists, whether warranted or not, that an IOM is difficult to measure.

The advantage of wet measurement is that the rules are based on it and if you want the waterline of a boat then it has to be floated.

Proponents of dry /waterless measuring cite the following advantages and requirements to encourage converting to it -

1. Any dry measuring system should minimize any advantage or disadvantage to existing and future designs, producing a method of measuring length, hull draught and bulb draught with minimal influence design concepts.
2. The measuring jig should be simple to make with simple tools and allow alternative jigs which arrive at the same results to be used.
3. It should be economic to produce.
4. It should give results with a repeatable accuracy for length, hull draught and maximum and minimum draught.
5. It should be portable and it should be easily and quick to set up.
7. It should be able to have boats being measured cycled through it quickly without loss of accuracy.
8. It should not need constant readjustment after every boat.
9. The boat would not need to be rigged.
10. Encourage measurement of all IOM yachts at all events.

The major sticking point is - where is the waterline without getting the boat wet! I doubt that you will solve this problem by simple means, so the approach is not to ignore it but to come up with a compromise that will not make all present IOMs obsolete and yet retain the basic concepts of hull control. This leads to the most common objection to dry measurement - that designers will come up with a way of designing around datum points to produce a "killer" boat. Designers dream about "killer" boats every time they work on a new design! I suggest that the datum points are so close to the average waterline ends that if this "killer" was / is possible then the present tank measurement would have already allowed it. Perhaps they should be more concerned with the "killer" skipper.

Ways around a dry measuring jig and other perceived problems.

Very narrow designs which sink down in the water thereby gaining extra ballast bulb depth and hull depth with correction weights placed low in the hull. I suspect that such a boat would suffer from increased wetted area and also be somewhat difficult to manoeuvre with its immersed ends.

A skeg like ending at the stern to hold the hull high in the jig - this again would suffer from an increased wetted surface and may well be directionally stable but again difficult to manoeuvre.

A long (1,000mm) waterline boat with a flat entry and exit may be lifted approximately 1.5mm at the bow making a difference at the bulb and lowest point of the rocker of less than 1 mm. Most would be less than this. From the above note the extra millimetre gained in the jig is of no consequence to existing boats as no one seems inclined to push the limit on hull draught. However, a lot of boats which have been checked in the jig, could be made more competitive by taking any gain. This would be quite likely when their skippers realize how far above the limit their bulbs really are in many cases - what is not seen in the bottom of a tank.

An existing short waterline, heavily rockered hull could potentially drop in the jig which might put them through the hull draught limit as set by the jig. The same could be said for the bulb draught. I have not seen any such designs, though I believe that they are likely to exist. I assume they would be highly manoeuvrable but somewhat lacking in straight line speed. They would suffer a loss of bulb draught in a measuring jig.

A Dry Measuring Jig



Elements in what follows appear in past files in the IOMICA Forum and elsewhere. What is suggested here is not the only device which will meet the requirement of checking a boats compliance, but it is convenient and quick to set up and simple to use. Boats can easily be cycled through in less than 20 seconds. It is also economic and simple to produce using common tools. The jig shown folds into a flat package with its own carrying case and is portable. **(Photo 1)** Clubs with storage facilities and no need for transporting the jig could simplify it by making it rigid and substituting a strong back for the case. However, some arrangement should be allowed for to adjust the base for flatness. In the prototype the carrying case is used as a strong back and the jig screwed down on it **(Photo 2 and 3)** and adjusted for flatness.



WCMYA Photo No. 3

It assumes a rule standard of accuracy which I suggest is reasonable.

The compromise involved is to establish two datum points which will substitute for the wet waterline and be as close as reasonable to an “average” wet waterline. These are referenced to the stem of the boat and are set at +20 (bow) and +990mm (stern). The stern datum is divided into two, set 40 mm apart. **(Photo 4)** This presents an “average” IOM with its stern lowest point at the datum height and the bow at the approximately 1 mm above datum measured at the rear of a 10mm bumper. **(Photo 5)** This then assumes a waterline of 980 mm. From these two datum points a secondary datum is set 420mm below these two points - this is the base of the jig and provides the limit for the bulb draught. **(Photo 2)** The hull draught can then be checked by measuring up from this secondary datum surface 360mm. **(Photo 6)** A check for minimum ballast bulb draught can be achieved by measuring up 50mm from the base. The gauge piece allows this to be done.



WCMYA Photo No. 4

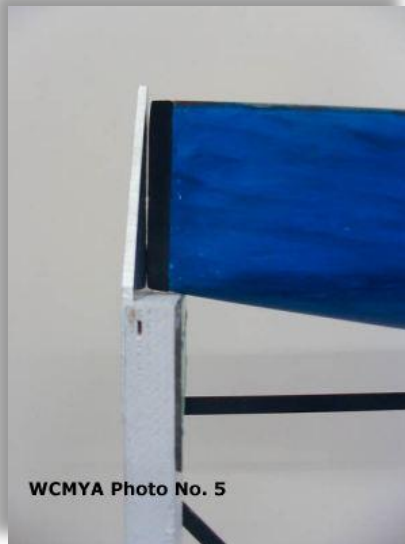

WCMYA Photo No. 5

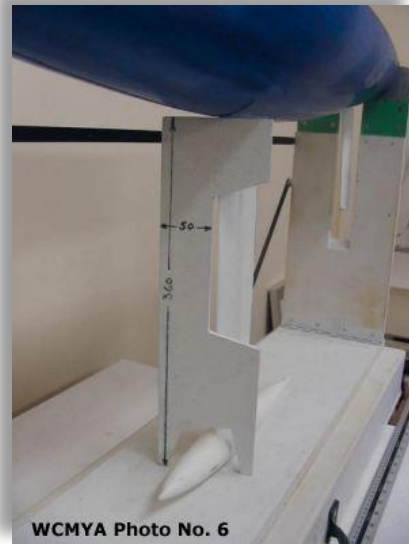

WCMYA Photo No. 6

By its construction the jig checks the maximum length of 1,000mm and the rudder overhang can be checked with a straight edge. **(Photo 8)**



For clarification of the above please refer to the photographs and drawings. For more queries please contact:
Lawrie Neish - vcmeasuring@iomclass.org

Note 1 - Hull draught

From observation of a large number of flotation's all but a few are 3mm clear or greater, and most are in the 3 to 5 mm range, at maximum rocker. Given this, it would seem that this is of lesser concern in measuring and with all boats so far jig and tank have correlated well. Of the three measurements checked by the jig, the hull draught is the one which would not be alterable after building

Note 2 - Bulb draught

Again from measuring, I have come across two which pushed the limit of bulb draught and passed - one of which failed in the same tank two years later. The fin draught is comparatively easy to alter and any existing boat could be modified simply to overcome any perceived disadvantage as practically all the boats which have been tried could have their fin lengthened.

Note 3 - Hull length

A boat fails if it is too long and as with existing tank measurement this is easily fixed providing you have enough bumper! This is perhaps the least contentious measurement

Note 4 - Rudder compliance

This is another check which can be made in the jig and probably not a contentious point in a move to dry measuring. If nothing else it is easier to do in the jig than in a tank.

Note 5 - Existing certificated boats

If a change was to be made then all existing certificated IOMs and those having completed certification via tank flotation before some,

to be set, date should be grand-parented providing they can still pass flotation. However, from what I have seen, most would probably wish to adapt to the dry process with reference to bulb draught.

Possible changes resulting from a move to dry measuring

With the simplicity of construction and low cost it is very likely that such a measuring jig would become much more widely available. From this increase availability it could be expected that measuring of boats might be expected to increase in lower level events benefiting fair sailing. I could foresee as a result of this that a large number of boats would be able to have their bulb draught more accurately set to close to the maximum making them more competitive. In fact the jig could be used to set bulbs.

Finally, I have always found it odd that a boat which is called an International One Metre does not on its fundamental measurement ask the measurer to check that it is in fact less than 1 metre overall, nor does it ask that the two draught limits stated in the class rules are complied with. Having, trucked a tank around (**Photo 9**) - all boats in Western Canada are floated when the fundamental measurement is done as convenience to owners and builder - I can understand why these checks are not performed. Perhaps in future, with the use of such a jig, these checks can be introduced into fundamental measurement.



Event measuring as I see it with the jig.

Most events have time constraints on checking boats conform to class rules

1. The fin and bulb weighed, followed by total boat weighing.
2. Fin fitted and length, bulb draught and hull draught checked. Rudder checked.
3. Sails measured by template.

I think the total time spent per boat would be between two and three minutes if one sail is measured and perhaps five minutes for all sails - depending on how organised are the skipper and measurer(s). If the measurer's stamp on the sails is accepted without question then the process would be shortened.

IOM Dry Measure Jig Plans

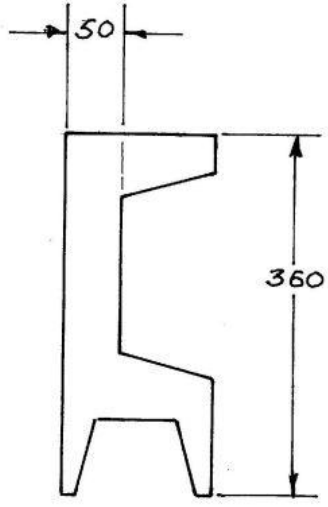

DRAUGHT GAUGE

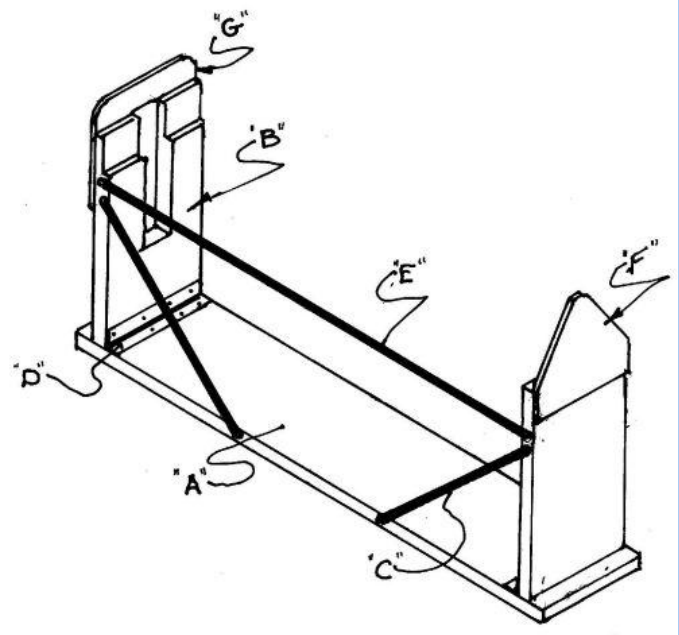

IOM DRY MEASURING JIG-1

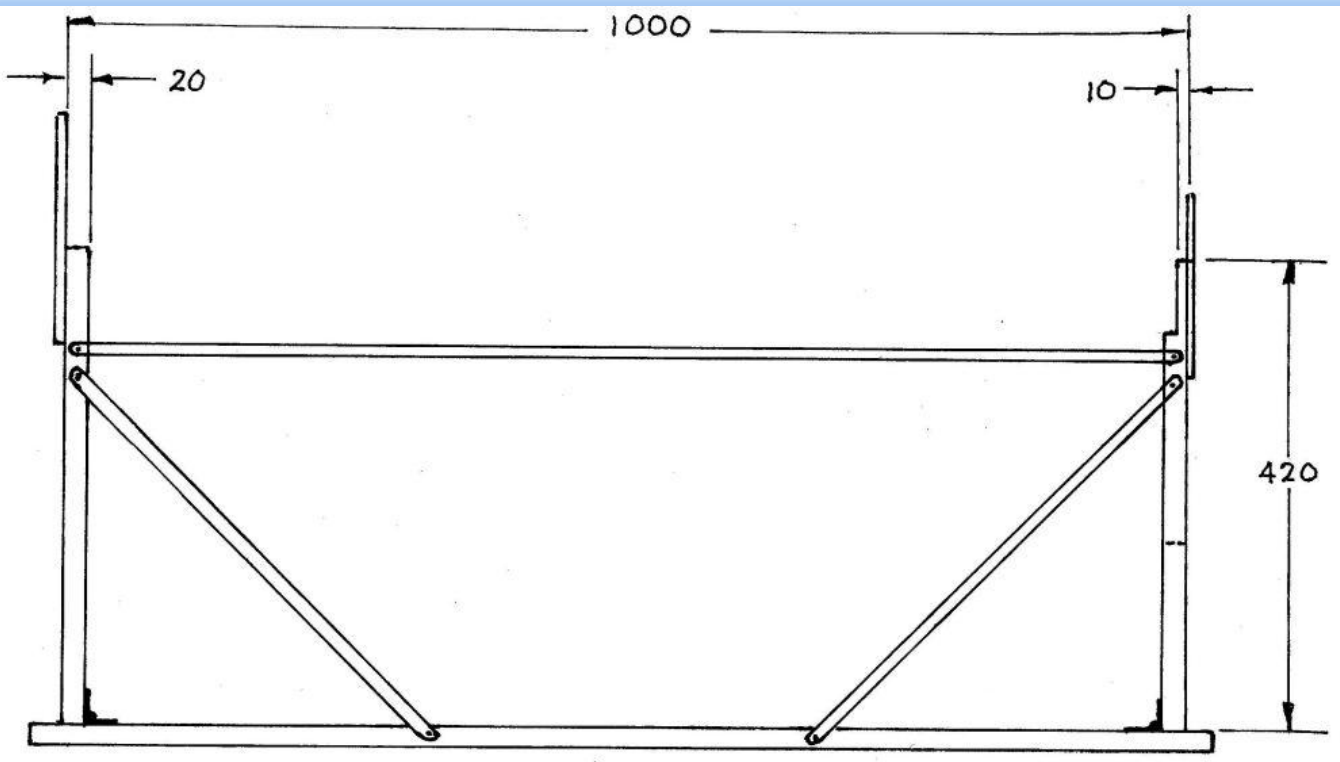

REAR VIEW

IOM DRY MEASURING JIG-2

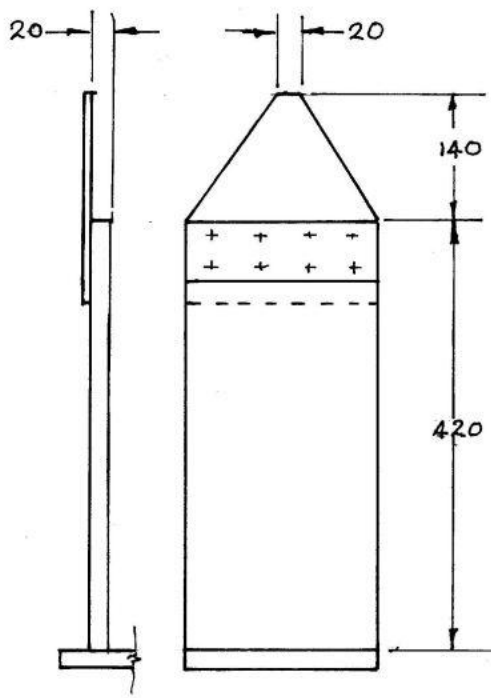

BOW

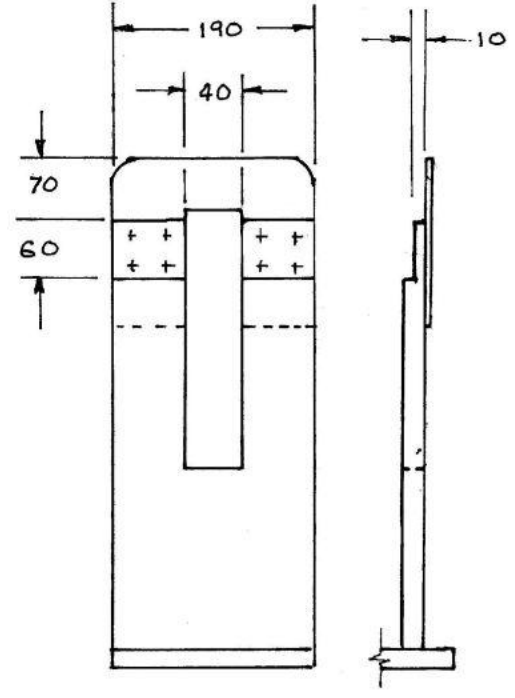

STERN

DATUM PLATES

10M DRY MEASURING JIG-3